

Amphenol

AQWLD SERIES



Amphenol

Introduction

Amphenol AQWLD heavy duty cylindrical connectors are with double stub threads with five key-keyways designed to meet the operating requirements of **MIL-C-22992**.

These connectors are primarily used in a wide range of military and industrial application where power and control functions are prerequisites with additional requirements of environmental protection.

AQWLD connectors are designed, manufactured and tested to **MIL-C-5015** and **MIL-C-22992** respectively. This series uses same insert patterns used for **MIL-C-5015** and used with high shock and vibration environment.

Page Contents

1	Introduction
2	General Description
3 - 4	Electrical Data
4 - 5	Technical Data
6	Insert Orientations
7 - 17	Insert Arrangements
18	Shell Types & Box Mount Receptacles
19	Cable Connecting Plug & Jam Nut
20	Panel Cut-out Dimensions & Jam Nut Receptacle (Wall Mount)
21	Plug Connector & Receptacle Dustcap
22	Plug Dustcap
23	Ordering Information for Dustcap
24 - 25	Contact Details
26	Ordering Information AQWLD Series Connectors

General Description

Amphenol AQWLD connectors are designed as per the characteristics and specification determined by US Military. These specifications are revised from time to time to incorporate performance requirements dictated by design advances and more stringent requirements of allied equipments.

Due to design versatility, high reliability and rugged construction this series is ideal for applications which demand high shock and vibration with environmental protection.

Shell

Shell constructions are manufactured from Aluminum alloy with black anodic finish. This finish is non conductive with high wear and corrosion resistance. Cadmium finish is also available on request. For details contact factory.

Shell style consist of wall and box mount receptacles, Jam nut receptacles, Cable connecting receptacles and Straight plugs. Connectors are available in shell sizes 12 thru 40. Shells have double stub thread for receptacle and coupling. In addition shell has five key and keyways for positive locking.

Insert

The inserts are moulded from Resilient polychloroprene. Offers high die electric strength and resistance to oils, gasoline and low temperature. This provides electrical isolation of the contacts in the insert and excellent moisture sealing.

Contacts

Pin and socket contacts are of copper alloys with gold plated crimp contacts. Solder available on request. Silver plated finish is also available. For details contact factory.

Features of AQWLD connectors

- Double start stub coupling thread for quick & positive coupling
- Waterproof
- High shock & vibration resistance
- Operating temperature range -55°C +125°C with neoprene rubber insert
- Available in both crimp & solder version
- Numerous finishes available
- Durability 500 mating, unmating cycle

 Electrical Data

Contact rating at 68° F (+20°C)

Contact Size AWG	Max. Current Contact A
16	22
12	41
8	74
4	135
0	245

Contact Resistance

Measured at cable end of a mated and harnessed connector pair.
Distance between the measuring points approx. 300mm.

Contact Size AWG	Max. Contact Resistance mΩ
16	6
12	3
8	1
4	0.3
0	0.2

Insulation Resistance

According to VG 95319 Part 2, Test Nr. 5.12 and VG 95210 Part 32.
Test condition B: $\geq 1000M\Omega$

Test Voltage

According to VG 95319 Part 2, Nr. 5.13 and VG 95210 Part 31.
Test for service rating:

Service Rating	Test Voltage V rms
Instrument	1050
A	1600
D	2500
E	3000

Air and Creepage Paths (min.)

Service rating	Instr.	A	D	E
Air path mm				
Creepage path mm	0.7	1.1	2.8	4.8

Recommended Wire Stripping

Either mechanical or hot stripping can be used. Prevents wire or insulator damage. For solder connection, wires have to be pretinned.

Note :

Do not twist wires used in crimp contacts. Do not touch uninsulated wires before crimping. Twisting of wires and grease or lubricants on the wires cause poor crimp quality.

Contact Size	Stripping Length in mm.
16	6.2
12	6.2
8	11.8
4	11.8
0	13.7

Alternate Insert Positions

Mismatching may occur if several connectors with the same contact arrangement are placed together. Alternate insert positions are available to avoid this. The different insert positions are identified with the letters W,X,Y & Z in addition, for certain contact arrangements special insert positions are available, identified with position numbers. Normal position is not specially indicated.

By rotation of the pin insulator in clockwise direction to the shell the socket insulator is rotated contrary to clock direction. This information refers to the mating side of the insulator.

Caused by symmetry problems not all insert positions can be applied for each contact arrangement positions.

Technical Data

Standard Data

Shells	Aluminium alloy
Finish	Hard anodic finish - Black
Insulator	Resilient polychloroprene (Hardness 75±5 shore)
Contacts	Copper alloy
Contact finish	2.54 Micron Gold plated (HARD) (0.0001 inch) at contact engagement area

Mechanical Features
Ambient Temperature
-55/125°C (-67/125°F)

Mating Cycles
Min. 500

Technical Data

Contact retention

The contact retention has to be tested according to VG 95319 Part 2, Test Nr. 5,4, Test force direction = Mating direction.

Contact size AWG	Test force N
16	35
12	55
8	80
4	90
0	95

Separating force per contact

The corresponding separating force has to be measured according to VG 95319, Part 2, Test Nr. 5.7. Using the required test gauge.

Contact size AWG	Separating force min. N
16	1.0
12	1.5
8	3.0
4	4.0
0	8.5

Condition	Configuration	Description	Reference
Thermal Shock	Unmated	Five complete one hour temperature cycles of -55° to +125°C	MIL-STD-1344, method 1003, test condition A
Moisture Resistance (Cable mounted connectors)	Mated	Ten complete 24 hour cycles of +25°C to +65°C Temperature at 90% to 98% humidity	MIL-STD-202, method 106,
Durability	Mated	500 complete mating / unmating cycles	MIL-STD-22992,
Salt Spray (Corrosion)	Unmated	48 hour exposure to atomized 5% saline solution at +35°C	MIL-STD-1344 method 1001
Vibration	Mated	10 to 55 Hz, 06 inch total excursion in 1 minute cycles for 6 hours, 55 to 2000 Hz, 10G peak amplitude sweep	MIL-STD-1344 method 2005
High Impact	Mated	Nine hammer blows from 1, 3 & 5 feet three each in three axes on mounting panel	MIL-STD-202 method 207
Fluid Immersion	Unmated	20 hours immersion in hydraulic fluid & lubricating oil	MIL-C-22992
Water Immersion	Mated & Unmated	4 hours immersion at 1 atmosphere pressure different	MIL-C-22992

Insert Orientations

To avoid cross-plugging problems in applications requiring the use of more than one connector of the same size and arrangement, alternate insert rotations are available as indicated in the accompanying chart.

As shown in the diagram below, the front face of the pin insert is rotated within the shell in a clockwise direction from the normal shell key. The socket insert would be rotated counterclockwise the same number of degrees with respect to the normal shell key.

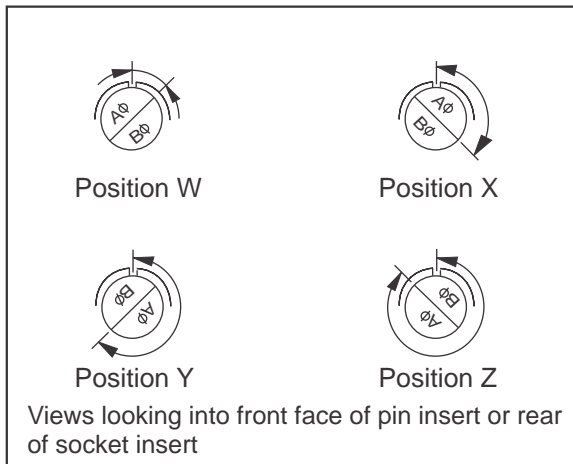

The following insert arrangements have the same alternate insert rotations for W, X, Y and Z which are as below :

Degree			
W	X	Y	Z
80	110	250	280

16-7	20-16	22-18	24-4	24-21	28-15	36-1
18-5	20-20	22-19	24-5	24-28	28-16	36-7
18-9	20-22	22-21	24-6	28-1	28-17	36-8
18-13	22-3	22-24	24-7	28-4	28-19	36-13
18-14	22-6	22-25	24-12	28-8	28-20	
20-7	22-12	22-29	24-14	28-9	28-21	
20-8	22-14	22-33	24-16	28-10	32-1	
20-9	22-15	22-34	24-17	28-11	32-3	
20-12	22-16	24-1	24-20	28-14	32-4	
20-14	22-17	24-3				

Insert Arrangement	Degrees			
	W	X	Y	Z
12S-3	70	145	215	290
14S-2	-	120	240	-
14S-5	-	110	-	-
14S-7	90	180	270	-
14S-9	70	145	215	290
16-9	35	110	250	325
16-10	90	180	270	-
16-11	35	110	250	325
16-13	35	110	250	325
16S-1	80	-	-	280
16S-4	35	110	250	325
16S-5	70	145	215	290
16S-6	90	180	270	-
16S-8	-	170	265	-
18-1	70	145	215	290
18-3	35	110	250	325
18-4	35	110	250	325
18-8	70	-	-	290
18-10	-	120	240	-
18-11	-	170	265	-
18-12	80	-	-	280
18-15	-	120	240	-
18-20	90	180	270	-
18-22	70	145	215	290
18-29	90	180	270	-
20-3	70	145	215	290
20-4	45	110	250	-
20-5	35	110	250	325

Insert Arrangement	Degrees			
	W	X	Y	Z
20-6	70	145	215	290
20-7	80	110	250	280
20-15	80	-	-	280
20-17	90	180	270	-
20-18	35	110	250	325
20-19	90	180	270	-
20-21	35	110	250	325
20-22	80	110	250	280
20-23	35	110	250	325
20-24	35	110	250	325
20-27	35	110	250	325
20-29	80	-	-	280
20A48	-	80	280	-
22-1	35	110	250	325
22-2	70	145	215	290
22-4	35	110	250	325
22-5	35	110	250	325
22-8	35	110	250	325
22-9	70	145	215	290
22-10	35	110	250	325
22-11	35	110	250	325
22-13	35	110	250	325
22-20	35	110	250	325
22-22	-	110	250	-
22-23	35	-	250	-
22-27	80	-	250	280
22-28	80	-	-	280
24-2	80	-	-	280

Insert Arrangement	Degrees			
	W	X	Y	Z
24-9	35	110	250	325
24-10	80	-	-	280
24-11	35	110	250	325
24-22	45	110	250	-
24-27	80	-	-	280
28-2	35	110	250	325
28-3	70	145	215	290
28-5	35	110	250	325
28-6	70	145	215	290
28-7	35	110	250	325
28-12	90	180	270	-
28-15	80	110	250	280
28-18	70	145	215	290
28-21	80	110	250	280
28-22	70	145	215	290
32-8	80	125	235	280
32-17	45	110	250	-
36-3	70	145	215	290
36-4	70	145	215	290
36-5	-	120	240	-
36-6	35	110	250	325
36-9	80	125	235	280
36-10	80	125	235	280
36-14	90	180	270	-
36-15	60	125	245	305
36A98	-	-	-	-
40-56	72	144	216	288

Insert Arrangements

Front face of pin insert or rear of socket insert illustrated

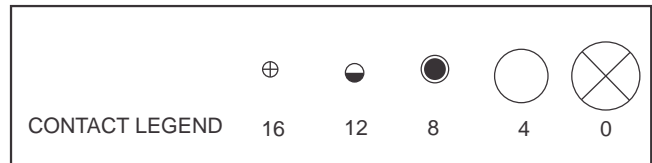

Insert arrangement	*12S-3	*12S-4	*12-5	*14S-A7	*14S-1	
Service rating	A	A	D	A	A	
Number of contacts	2	1	1	7	3	
Contact size	16	16	12	16	16	
Premating contact	-	-	-	-	-	
Insert arrangement	*14S-2	*14S-4	*14S-5	*14S-6	*14S-7	
Service rating	Inst.	D	Inst.	Inst.	A	
Number of contacts	4	1	5	6	3	
Contact size	16	16	16	16	16	
Premating contact	-	-	-	-	B	
Insert arrangement	*14S-9	*14S-10	*14S-12	*14-3	*16S-1	
Service rating	A	100 ⁰ rotation of 14S-2 Inst.	100 ⁰ rotation of 14S-7 A	A	A	
Number of contacts	2	4	3	1	7	
Contact size	16	16	16	8	16	
Premating contact	-	-	B	-	G	
Insert arrangement	*16S-3	*16S-4	*16S-5	*16S-6	*16S-8	*16-2
Service rating	B	D	A	A	A	E
Number of contacts	1	2	3	3	5	1
Contact size	16	16	16	16	16	12
Premating contact	-	-	A	B	E	-

*Not tooled up, can be tooled up on request. Contact Factory.

Insert Arrangements

Front face of pin insert or rear of socket insert illustrated

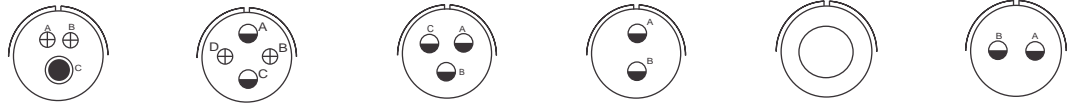
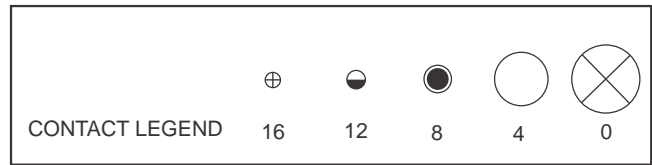

Insert arrangement	*16-7	*16-9	16-10	*16-11	*16-12	*16-13
Service rating	A	A	A	A	A	A
Number of contacts	1 2	2 2	3	2	1	2
Contact size	8 16	12 16	12	12	4	12
Premating contact	C	-	B	-	-	-

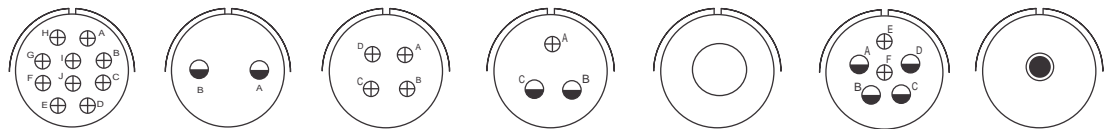

Insert arrangement	*18-1	*18-3	*18-4	*18-5	*18-6	*18-06	*18-7
Service rating	B,C,F,G=A; Bal.=Inst.	D	D	D	D	A	B
Number of contacts	10	2	4	2 1	1	2 4	1
Contact size	16	12	16	12 16	4	16 12	8
Premating contact	-	-	A	C	-	-	-



Insert arrangement	*18-8	*18-9	*18-10	*18-11	*18-12	*18-13
Service rating	A	Inst.	A	A	A	A
Number of contacts	1 7	2 5	4	5	6	1 3
Contact size	12 16	12 16	12	12	16	8 12
Premating contact	H	-	D	E	C or D	A



100° rotation of 18-9

Insert arrangement	*18-14	*18-15	*18-16	*18-17	*18-19	*18-20
Service rating	A	A	C	Inst.	A	A
Number of contacts	1 1	4	1	2 5	10	5
Contact size	4 16	12	12	12 16	16	16
Premating contact	-	-	-	-	K	D

*Not tooled up, can be tooled up on request. Contact Factory.

Insert Arrangements

Front face of pin insert or rear of socket insert illustrated

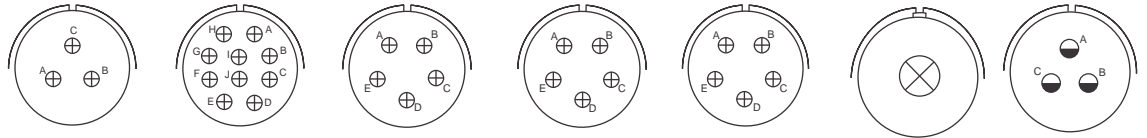
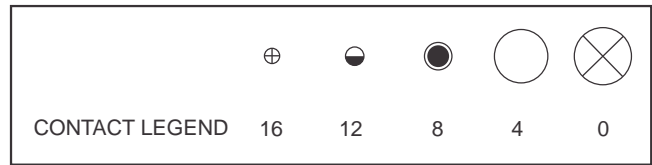

	*18-22	250° rotation of 18-1 *18-24	*18-29	110° rotation of 18-20 *18-30	260° rotation of 18-20 *18-31	*20-2	*20-3
Insert arrangement	D	B,C,F,G=A; Bal.=Inst.	A	A	A	D	D
Service rating	D		A	A	A	D	D
Number of contacts	3	10	5	5	5	1	4
Contact size	16	16	16	16	16	0	12
Premating contact	C	—	D	C	C	—	A

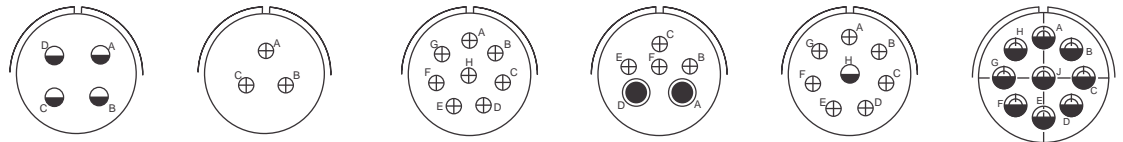

	*20-4	*20-6	20-7	*20-8	*20-9	*20-A 9
Insert arrangement	D	D	A,B,H,G=D; C,D,E,F=A	Inst.	H=D; Bal.=A	A
Service rating	D	D	A	Inst.	H=D; Bal.=A	A
Number of contacts	4	3	8	2 4	1 7	9
Contact size	12	16	16	8 16	12 16	12
Premating contact	C or D	A	A	—	H	—



	*20-11	*20-12	*20-14	*20-15	*20-16	*20-17
Insert arrangement	Inst.	A	A	A	A	A
Service rating	Inst.	A	A	A	A	A
Number of contacts	13	1 1	2 3	7	2 7	5 1
Contact size	16	4 16	8 12	12	12 16	12 16
Premating contact	—	—	D	A or D	E	E or F

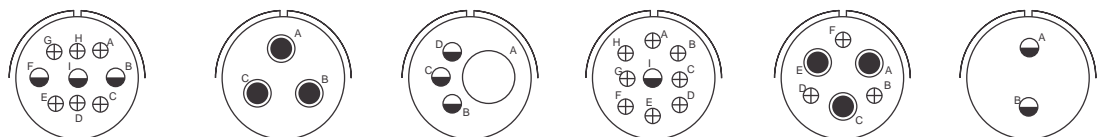

	*20-18	*20-19	*20-20	*20-21	*20-22	*20-23
Insert arrangement	A	A	A	A	A	A
Service rating	A	A	A	A	A	A
Number of contacts	3 6	3	1 3	1 8	3 3	2
Contact size	12 16	8	4 12	12 16	8 16	8
Premating contact	D	C	A	1	—	—

*Not tooled up, can be tooled up on request. Contact Factory.

Insert Arrangements

Front face of pin insert or rear of socket insert illustrated

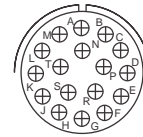
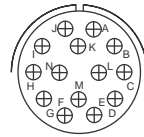
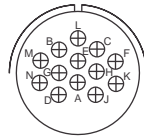
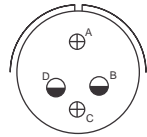
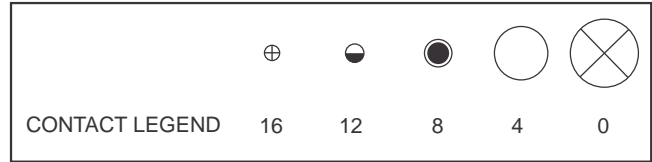

100° rotation of 20-11

250° rotation of 20-11

Insert arrangement
Service rating
Number of contacts
Contact size
Premating contact

*20-24
A
2 2
8 16
-

*20-25
Inst.
13
16
-

*20-27
A
14
16
M

20-29
A
17
16
G

*20-30
Inst.
13
16

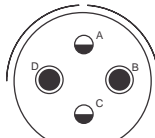
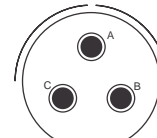
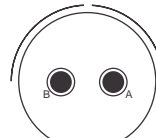
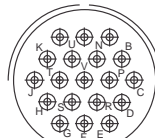
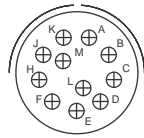

Insert arrangement
Service rating
Number of contacts
Contact size
Premating contact

*20-33
A
11
16
E

20A48
A
19
16
-

*22-1
D
2
8
-

*22-2
D
3
8
A

*22-4
A
2 2
8 12
C

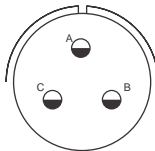
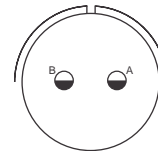
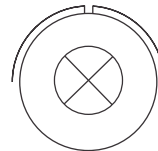
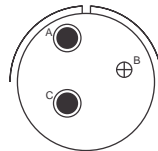
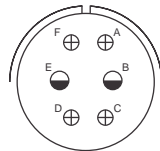

Insert arrangement
Service rating
Number of contacts
Contact size
Premating contact

*22-5
D
2 4
12 16
D

*22-6
D
2 1
8 16
B

*22-7
E
1
0
-

*22-8
E
2
12
-

*22-9
E
3
12
A

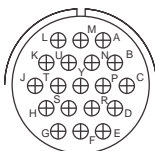
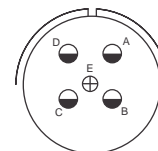
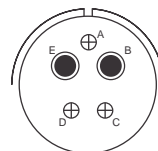
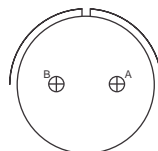
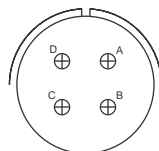

Insert arrangement
Service rating
Number of contacts
Contact size
Premating contact

*22-10
E
4
16
C

*22-11
B
2
16
-

*22-12
D
2 3
8 16
A

*22-13
E=D; A, B, C, D=A
4 1
12 16
E

*22-14
A
19
16
A

*Not tooled up, can be tooled up on request. Contact Factory.

Insert Arrangements

Front face of pin insert or rear of socket insert illustrated

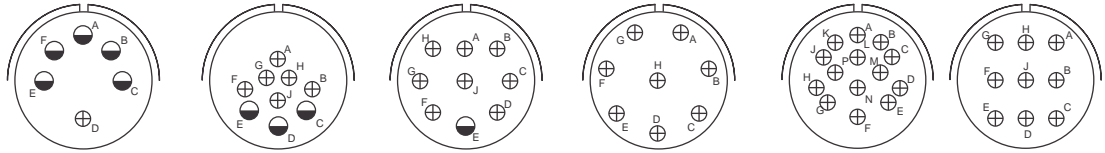
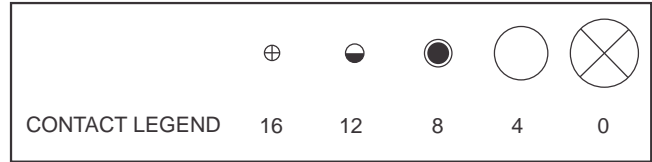

Insert arrangement	*22-15	*22-16	*22-17	*22-18	*22-19	*22-20
Service rating	D=E;A,B,C,E,F=A	A	A=D;Bal.=A	A,B,F,G,H=D;C,D,E=A	A	A
Number of contacts	5 1	3 6	1 8	8	14	9
Contact size	12 16	12 16	12 16	16	16	16
Premating contact	D	D	E	D	F	D

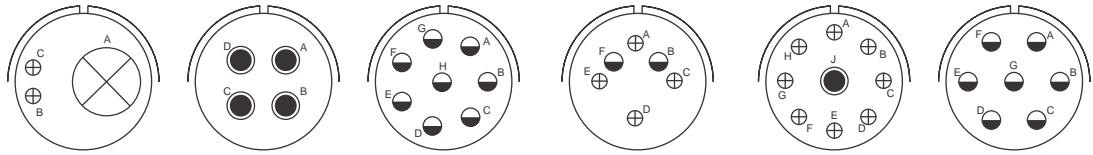

Insert arrangement	*22-21	22-22	22-23	*22-24	*22-27	*22-28
Service rating	A	A	H=D;Bal.=A	C,D,E=D;A,B,F=A	J=D;Bal.=A	A
Number of contacts	1 2	4	8	2 4	1 8	7
Contact size	0 16	8	12	12 16	8 16	12
Premating contact	-	C or D	A or D	D		G

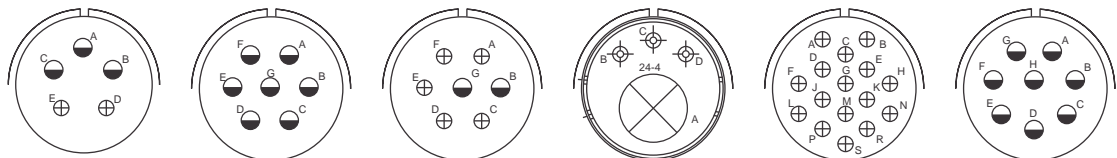

Insert arrangement	*22-34	*24-2	*24-3	*24-4	*24-5	*24-6
Service rating	D	D	D	A	A	A,G,H=D;Bal.=A
Number of contacts	3 2	7	2 5	3 1	16	8
Contact size	12 16	12	12 16	16 0	16	12
Premating contact	E	A	D	-	S	D

*Not tooled up, can be tooled up on request. Contact Factory.

Insert Arrangements

Front face of pin insert or rear of socket insert illustrated

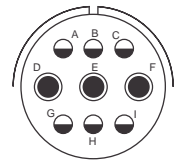
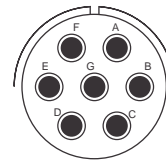
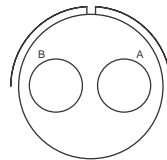
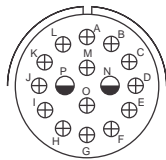
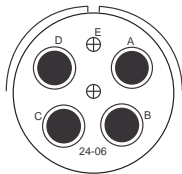

Insert arrangement
Service rating
Number of contacts
Contact size
Premating contact

*24-06
A
2 4
16 8
-

*24-7
A
2 14
12 16
G

*24-9
A
2
4
-

*24-10
A
7
8
D or E or G

*24-11
A
3 6
8 12
E

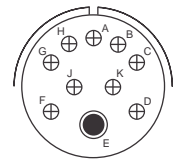
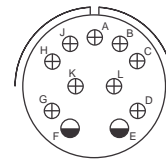
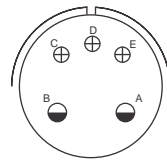
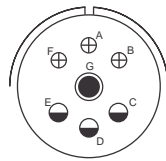
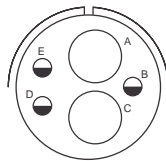

Insert arrangement
Service rating
Number of contacts
Contact size
Premating contact

*24-12
A
2 3
4 12
-

*24-16
A,B,F,G=D;C,D,E=A
1 3 3
8 12 16
G

*24-17
D
2 3
12 16
D

*24-20
D
2 9
12 16
A

*24-21
D
1 9
8 16
E

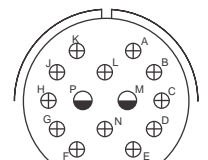
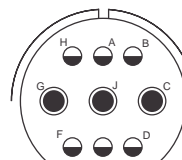
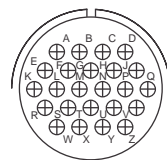
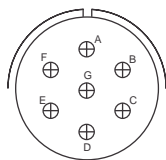
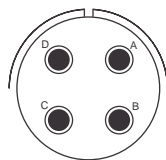

Insert arrangement
Service rating
Number of contacts
Contact size
Premating contact

*24-22
D
4
8
D

*24-27
E
7
16
D

*24-28
Inst.
24
16
-

*28-1
A,J,E=D;Bal.=A
3 6
8 12
E

*28-2
D
2 12
12 16
E

*Not tooled up, can be tooled up on request. Contact Factory.

Insert Arrangements

Front face of pin insert or rear of socket insert illustrated

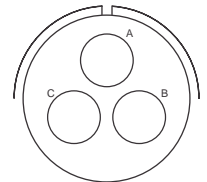
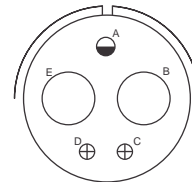
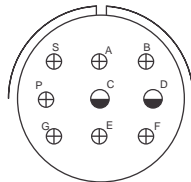
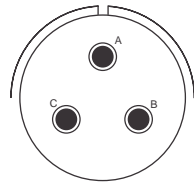
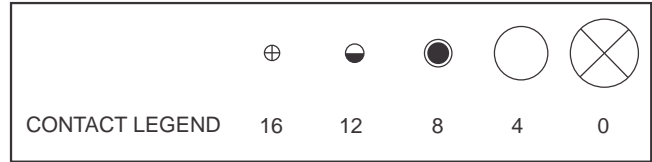

Insert arrangement
Service rating
Number of contacts
Contact size
Premating contact

*28-3
E
3
8
A

*28-4
G,S,P=E;Bal.=D
2 7
12 16
E

*28-5
D
2 1 2
4 12 16
-

*28-6
D
3
4
A

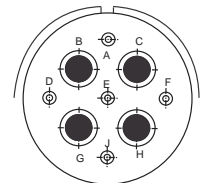
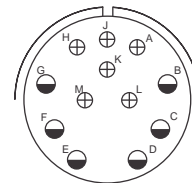
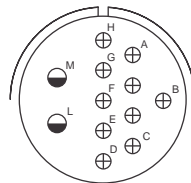
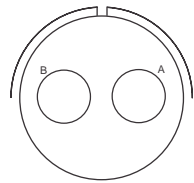

Insert arrangement
Service rating
Number of contacts
Contact size
Premating contact

*28-7
D
2
4
-

*28-8
L,M=E;B=D;Bal.=A
2 10
12 16
D

*28-9
D
6 6
12 16
E

*28-09
A
5 4
16 8
-

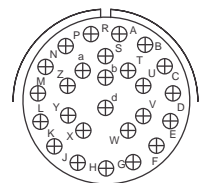
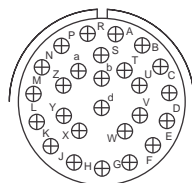
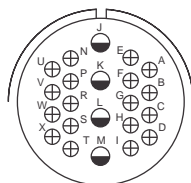
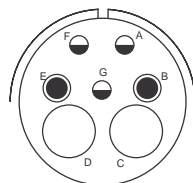

100° rotation
of 28-12

Insert arrangement
Service rating
Number of contacts
Contact size
Premating contact

*28-10
G=D;Bal.=A
2 2 3
4 8 12
G

*28-11
A
4 18
12 16
M

*28-12
A
26
16
H

*28-13
A
26
16
H

*Not tooled up, can be tooled up on request. Contact Factory.

Insert Arrangements

Front face of pin insert or rear of socket insert illustrated

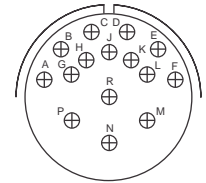
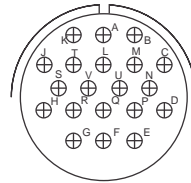
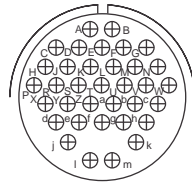
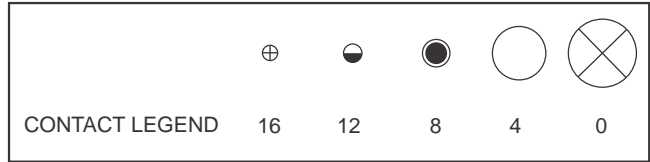

Insert arrangement
Service rating
Number of contacts
Contact size
Premating contact

***28-15**
A
35
16
M

***28-16**
A
20
16
F

***28-17**
R=B;M,N,P=D;A to L=A
15
16
N

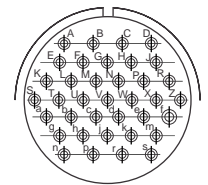
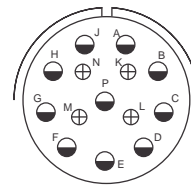
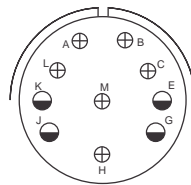
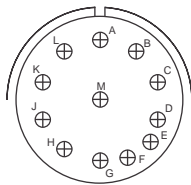

Insert arrangement
Service rating
Number of contacts
Contact size
Premating contact

***28-18**
M=C;G,H,J,K,L=
D;A,B=ABal.=Inst.
12
16
-

***28-19**
H,M=B;A,B=D;Bal.=A
4 6
12 16
H

***28-20**
A
10 4
12 16
E

28-21
A
37
16
A

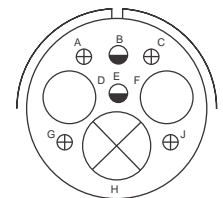
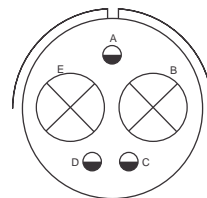
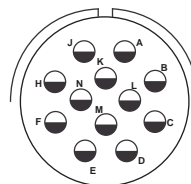
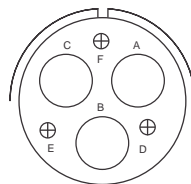

Insert arrangement
Service rating
Number of contacts
Contact size
Premating contact

***28-22**
D
3 3
4 16
-

***28-51**
D
12
12
-

***32-1**
A=E;B,C,D,E=A
2 3
0 12
-

***32-3**
D
1 2 2 4
0 4 12 16
-

*Not tooled up, can be tooled up on request. Contact Factory.

Insert Arrangements

Front face of pin insert or rear of socket insert illustrated

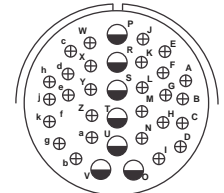
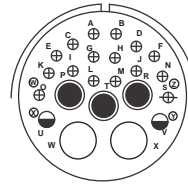
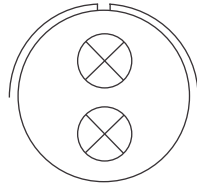

Insert arrangement
Service rating
Number of contacts
Contact size
Premating contact

***32-5**
D
2
0
-

***32-6**
A
16 2 3 2
16 12 8 4
-

***32-7**
INST, A
4 24 7
16 12
-

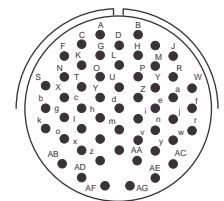
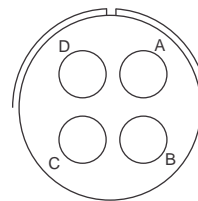
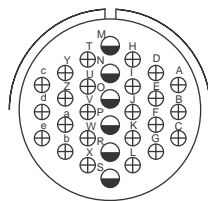

Insert arrangement
Service rating
Number of contacts
Contact size
Premating contact

***32-8**
A
6 24
12 16
S

32-17
D
4
4
-

***32-22**
A
54
16
-

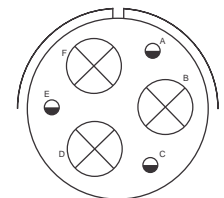
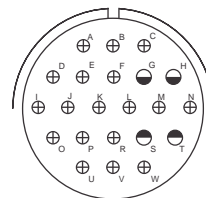
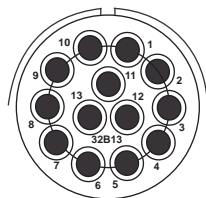

Insert arrangement
Service rating
Number of contacts
Contact size
Premating contact

***32B-13**
D
13
8
-

***36-1**
D
4 18
12 16
-

***36-3**
D
3 3
0 12
-

*Not tooled up, can be tooled up on request. Contact Factory.

Insert Arrangements

Front face of pin insert or rear of socket insert illustrated

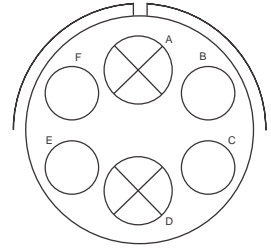
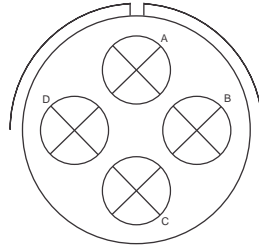
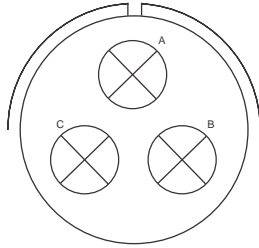

Insert arrangement
Service rating
Number of contacts
Contact size
Premating contact

***36-4**
A=D;B,C=A
3
0
-

***36-5**
A
4
0
-

***36-6**
A
2 4
0 4
-

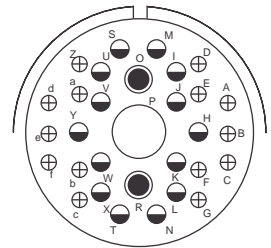
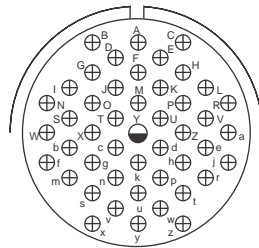
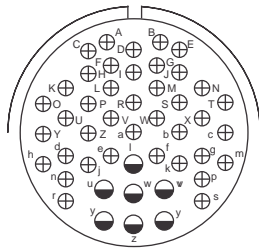

Insert arrangement
Service rating
Number of contacts
Contact size
Premating contact

***36-7**
A
7 40
12 16
x or y

***36-8**
A
1 46
12 16
Y

***36-9**
A
1 2 14 14
4 8 12 16
P

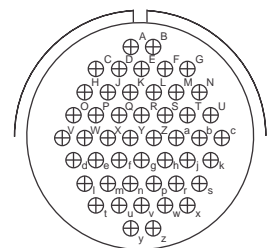
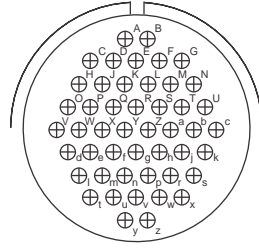
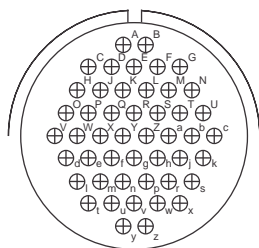

Insert arrangement
Service rating
Number of contacts
Contact size
Premating contact

***36-10**
A
48
16
A

100°rotation
of 36-10

***36-11**
A
48
16
A

250°rotation
of 36-10

***36-12**
A
48
16
A

*Not tooled up, can be tooled up on request. Contact Factory.

Insert Arrangements

Front face of pin insert or rear of socket insert illustrated

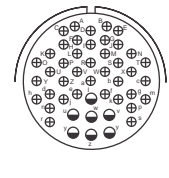
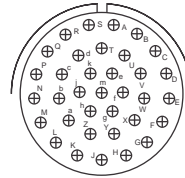
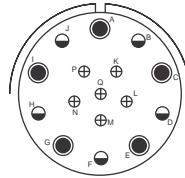
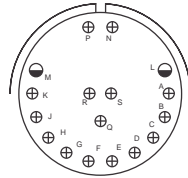
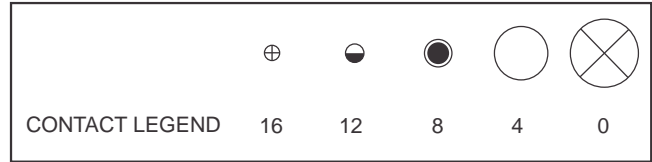

100° rotation of 36-7

Insert arrangement
Service rating
Number of contacts
Contact size
Premating contact

***36-13**
N,P,Q=E; Bal.=A
2 15
12 16
-

***36-14**
D
5 5 6
8 12 16
-

***36-15**
M=D; Bal=A
35
16
J

***36-16**
A
7 40
12 16
x or y

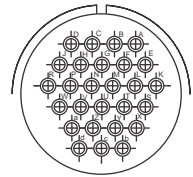
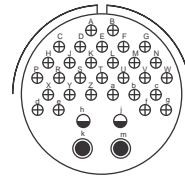
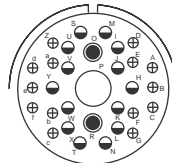
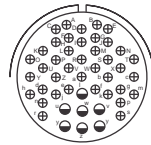

250° rotation of 36-7

100° rotation of 36-9

Insert arrangement
Service rating
Number of contacts
Contact size
Premating contact

***36-17**
A
7 40
12 16
x or y

***36-18**
A
1 2 14 16
4 8 12 16
-

***36-20**
A
2 2 30
8 12 16
k

***36-46**
A
27
16
-

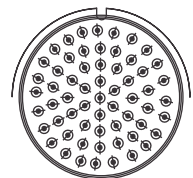
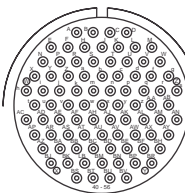
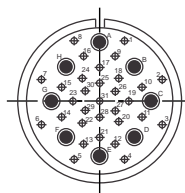
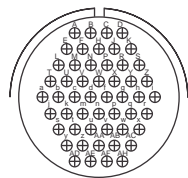

Insert arrangement
Service rating
Number of contacts
Contact size
Premating contact

***36-52**
A
52
16
-

36A98
INST
31 8
16 8
-

***40-56**
A
85
16
-

***40-63**
A
61
16
-

*Not tooled up, can be tooled up on request. Contact Factory..

Shell Types

Wall Mount Receptacle (AQWLD00)

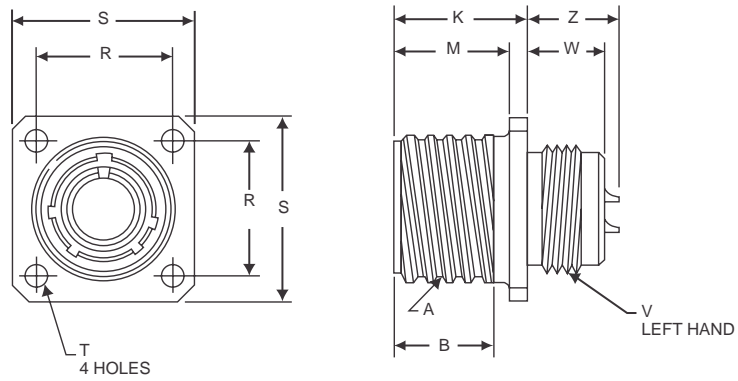

All dimensions are in mm

Shell Size	A Thread Class 2A (Plated) 0.1P-0.2L Double Stub	B Min Full Thd	K +.021 -0.020	M +.010 -0.000	R (TP)	S +.021 -0.020	T Dia +.004 -0.003	V Thread Class 2A-LH (Plated)	W ±.010	Z Max
12	.8750	17.07	23.80	20.24	23.01	30.18	3.81	.750-20UNEF	16.26	17.78
14	1.0000	17.07	23.80	20.24	24.61	32.54	3.81	.875-20UNEF	16.26	17.78
16	1.1250	17.07	23.80	20.24	26.97	34.93	3.81	1.000-20UNEF	16.26	17.78
18	1.2500	17.07	24.21	20.24	29.36	38.10	4.50	1.125-18UNEF	15.88	17.42
20	1.3750	17.07	24.21	20.24	31.75	41.28	4.50	1.250-18UNEF	15.88	17.42
22	1.5000	17.07	24.21	20.24	34.93	44.45	4.50	1.375-18UNEF	15.88	17.42
24	1.7500	17.07	26.59	21.82	39.67	50.80	4.50	1.625-18UNEF	15.09	14.86
28	2.0000	17.07	26.59	21.82	44.45	57.15	4.50	1.875-16UN	15.09	15.01
32	2.2500	17.07	28.17	23.42	49.23	63.50	5.31	2.0625-16UNS	13.46	13.41
36	2.5000	17.07	28.17	23.42	55.58	69.85	5.31	2.3125-16UNS	13.46	13.41
40	2.7500	17.07	28.17	23.42	60.33	76.20	5.31	2.625-16UN	17.86	13.41
44	3.0000	17.07	28.17	23.42	66.68	82.55	5.31	2.875-16UN	17.86	19.56

Box Mount Receptacle (AQWLD02)

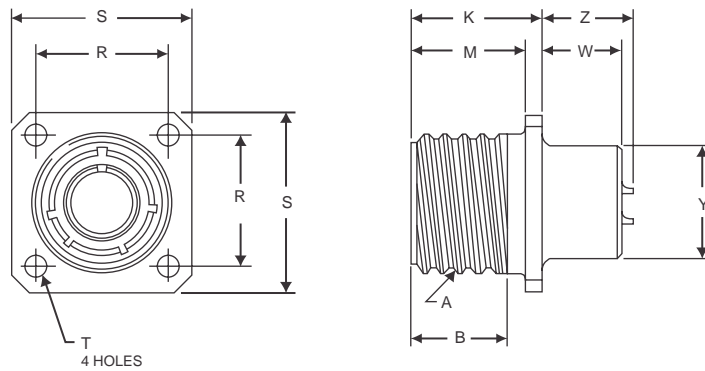

All dimensions are in mm

Shell Size	A Thread Class 2A (Plated) 0.1P-0.2L Double Stub	B Min Full Thd	K +.021 -0.010	M +.010 -0.000	R (TP)	S +.021 -0.020	T Dia +.004 -0.003	W ±.010	Y +.011 -0.010	Z Max
12	.8750	17.07	23.80	20.24	23.01	30.18	3.81	16.26	16.26	17.78
14	1.0000	17.07	23.80	20.24	24.61	32.54	3.81	16.26	19.43	17.78
16	1.1250	17.07	23.80	20.24	26.97	34.93	3.81	16.26	22.61	17.78
18	1.2500	17.07	24.21	20.24	29.36	38.10	4.50	15.88	25.78	17.42
20	1.3750	17.07	24.21	20.24	31.75	41.28	4.50	15.88	29.74	17.42
22	1.5000	17.07	24.21	20.24	34.93	44.45	4.50	15.88	32.92	17.42
24	1.7500	17.07	26.59	21.82	39.67	50.80	4.50	15.09	36.09	14.86
28	2.0000	17.07	26.59	21.82	44.45	57.15	4.50	15.09	41.28	15.01
32	2.2500	17.07	28.17	23.42	49.23	63.50	5.31	13.46	48.03	13.41
36	2.5000	17.07	28.17	23.42	55.58	69.85	5.31	13.46	52.78	13.41
40	2.7500	17.07	28.17	23.42	60.33	76.20	5.31	17.86	58.72	13.41
44	3.0000	17.07	28.17	23.42	66.68	82.55	5.31	17.86	65.07	19.56

Cable Connecting Plug (AQWLD01)

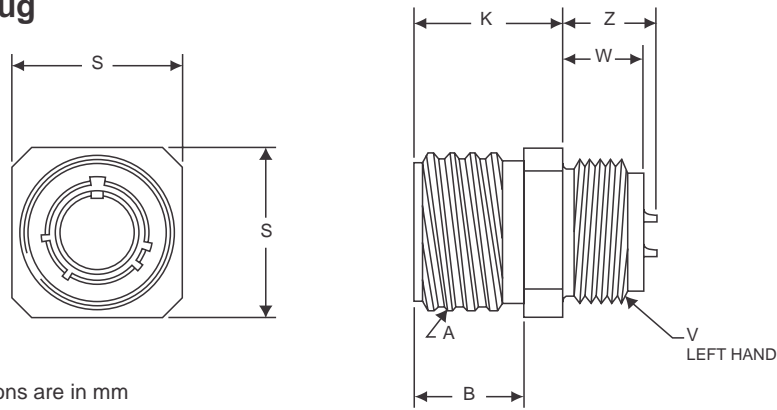

All dimensions are in mm

Shell Size	A Thread Class 2A (Plated) 0.1P-0.2L Double Stub	B +.016 -0.000	K +.021 -0.010	S +.021 -0.020	V Thread Class 2A-LH (Plated)	W ±.010	Z Max
12	.8750	17.48	23.83	25.40	.750-20UNEF	16.28	17.68
14	1.0000	17.48	23.83	27.79	.875-20UNEF	16.28	17.68
16	1.1250	17.48	23.83	32.54	1.000-20UNEF	16.28	17.68
18	1.2500	17.86	24.31	34.93	1.125-18UNEF	15.88	17.27
20	1.3750	17.86	24.31	38.10	1.250-18UNEF	15.88	17.27
22	1.5000	17.86	24.31	41.28	1.375-18UNEF	15.88	17.27
24	1.7500	19.46	24.31	47.63	1.625-18UNEF	15.88	15.67
28	2.0000	19.46	25.81	53.98	1.875-16UN	15.88	15.67
32	2.2500	17.86	25.81	60.33	2.0625-16UN	14.30	14.10
36	2.5000	17.86	27.38	66.68	2.3125-16UN	14.30	14.10
40	2.7500	17.86	27.38	76.20	2.625-16UN	17.86	14.10
44	3.0000	17.86	27.38	82.55	2.875-16UN	17.86	20.45

Jam Nut Receptacle (AQWLD07)

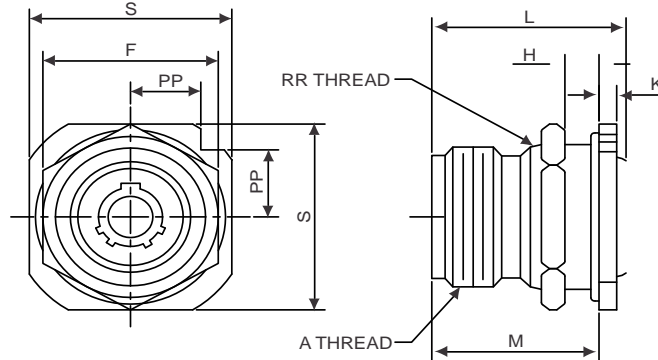

All dimensions are in mm

Shell Size	A Thread 2A	F MAX.	H MIN.	H MAX.	K ±0.15	L MAX.	M ±0.25	S MAX.	PP ±0.25	RR Thread 2A
12	0.875-0.1 P-0.2L-DS	31.8	2.4	7.5	3.2	40.4	31.4	35.3	12.3	1.00-20 UNEF
14	1.000-0.1 P-0.2L-DS	33.3	2.4	7.5	3.2	40.4	31.4	38.5	13.5	1.125-18 NEF
16	1.125-0.1 P-0.2L-DS	38.1	2.4	7.5	4.8	40.4	31.4	44.8	15.8	1.250-18 NEF
18	1.250-0.1 P-0.2L-DS	39.7	2.4	6.8	4.8	40.4	30.6	48.0	16.8	1.375-18 NEF
20	1.375-0.1 P-0.2L-DS	44.5	2.4	6.8	4.8	40.4	30.6	51.2	18.0	1.500-18 NEF
22	1.500-0.1 P-0.2L-DS	47.6	2.4	6.8	4.8	40.4	30.6	54.4	19.1	1.625-18 NEF
24	1.750-0.1 P-0.2L-DS	54.0	2.4	8.3	4.8	42.0	32.2	60.7	21.3	1.875-16 UN
28	2.000-0.1 P-0.2L-DS	60.3	2.4	8.3	5.6	42.0	33.8	67.1	23.6	2.125-16 UN
32	2.250-0.1 P-0.2L-DS	66.7	2.4	8.3	5.6	42.0	33.8	73.4	25.8	2.375-16 UN
36	2.500-0.1 P-0.2L-DS	73.0	2.4	8.3	5.6	42.0	33.8	79.8	28.0	2.625-16 UN
40	2.750-0.1 P-0.2L-DS	79.0	2.4	8.3	5.6	42.0	33.8	86.9	30.8	2.875-16 UN

Panel cut-out dimensions

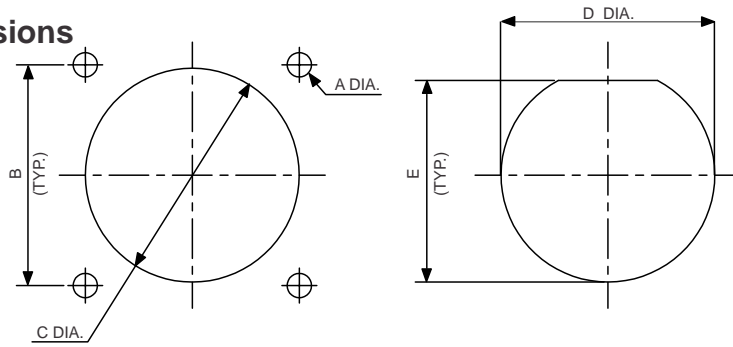

All dimensions are in mm

Shell Size	A Dia. Hole Size	Connector Styles			
		02 & 00	Front mount 02 & 00	Jam Nut 07	Jam Nut 07
		B±0.10	C Dia.	D Dia.	E Dia.
10SL	3.20	18.21	17.46	22.22	21.08
14S	3.20	23.01	20.64	28.57	27.43
16S/16	3.20	24.61	23.81	27.20	30.73
18	3.20	27.00	26.49	34.92	33.53
20	3.20	29.39	30.16	38.10	36.83
22	3.20	31.80	33.34	41.27	39.88
24	3.71	34.90	36.51	44.45	43.18
28	3.71	39.70	42.86	50.80	49.53
32	4.29	44.50	49.21	57.15	55.88
36	4.29	49.20	53.18	57.15	62.23
40	4.29	55.50	60.33	69.85	68.58

Jam Nut Receptacle (Wall Mount) (AQWLD07E)

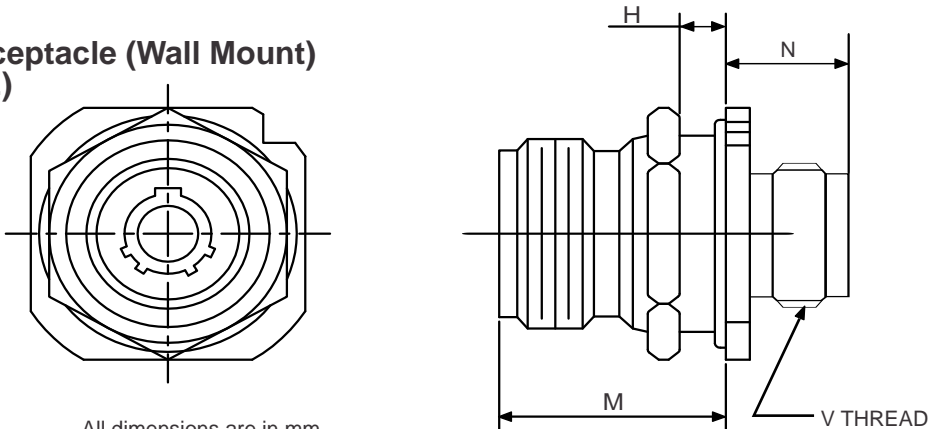

All dimensions are in mm

Part No.	Shell Size	M ±0.25	N ±0.50	V Thread 2A (LH)	H Min.	H Max.
AQWLDE07R12*	12	28.98	16.28	0.750-20 UNEF	2.39	4.78
AQWLDE07R14*	14			0.875-20 UNEF		
AQWLDE07R16*	16			1.000-20 UNEF		
AQWLDE07R18*	18	29.36	17.86	1.125-18 NEF		5.16
AQWLDE07R20*	20			1.250-18 NEF		
AQWLDE07R22*	22			1.375-18 NEF		
AQWLDE07R24*	24	30.96		1.625-18 NEF		6.73
AQWLDE07R28*	28	31.27	19.94	1.875-16 UN		7.04
AQWLDE07R32*	32			2.0625-16 N		5.46
AQWLDE07R36*	36			2.3125-16 N		
AQWLDE07R40*	40			2.625-16 UN		

All other dimensions are as per AQWLD07 refer page no.19

**Straight Plug Connector
(AQWLD06)**

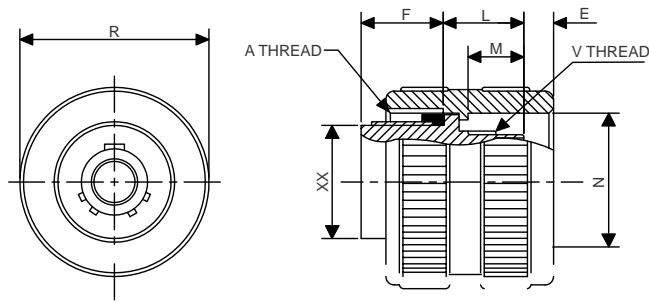

All dimensions are in mm

Shell Size	A Thread 2B	E MAX.	F MAX.	L ±0.25	M REF.	N +0.4	R MAX.	V Thread LH Class 2A	XX -0.3
12	0.875-0.1 P-0.2L-DS	2.5	19.6	18.8	13.2	24.9	29.4	0.750 - 20 UNEF	14.1
14	1.000-0.1 P-0.2L-DS	2.5	19.6	18.8	13.2	28.1	32.5	0.875 - 20 UNEF	17.1
16	1.125-0.1 P-0.2L-DS	3.8	19.6	18.8	13.2	31.3	37.3	1.00 - 20 UNEF	20.4
18	1.250-0.1 P-0.2L-DS	7.0	19.6	18.8	13.2	34.4	39.7	1.125 - 18 NEF	23.6
20	1.375-0.1 P-0.2L-DS	7.0	19.6	18.8	13.2	37.6	42.9	1.250 - 18 NEF	26.7
22	1.500-0.1 P-0.2L-DS	7.0	19.6	18.8	13.2	40.8	46.8	1.375 - 18 NEF	29.8
24	1.750-0.1 P-0.2L-DS	7.0	19.6	20.3	13.2	47.1	53.2	1.625 - 18 NEF	33.0
28	2.000-0.1 P-0.2L-DS	7.0	19.6	20.3	13.2	53.5	59.5	1.875 - 16 UN	38.6
32	2.250-0.1 P-0.2L-DS	7.0	19.6	22.2	13.4	59.8	65.9	2.062 - 16 UN	45.0
36	2.500-0.1 P-0.2L-DS	7.0	19.6	22.2	13.4	66.2	72.2	2.312 - 16 N	50.3
40	2.750-0.1 P-0.2L-DS	2.5	19.6	26.4	16.8	74.1	81.0	2.625 - 16 UN	56.6

**Amphenol AQWLD Dustcap MIL-C-22992
Receptacle Dustcap
(AQWLD-17349)**

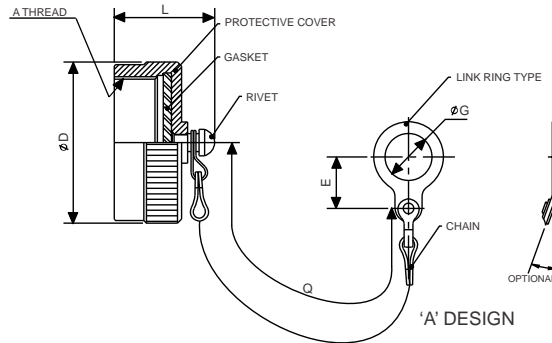

All dimensions are in mm

Amphenol Part No.	MS Part No.	A Thread 2B Double Start	ØD MAX.	E MIN.	L MAX.	ØG MIN.	Q
AQWLD-17349C12*	MS17349C12*	0.875-0.1P-0.2L-DS	27.80	21.10	19.43	25.80	127.00
AQWLD-17349C14*	MS17349C14*	1.000-0.1P-0.2L-DS	31.00	22.10		29.00	
AQWLD-17349C16*	MS17349C16*	1.1250-0.1P-0.2L-DS	34.10	24.60		32.20	
AQWLD-17349C18*	MS17349C18*	1.250-0.1P-0.2L-DS	37.30	25.70	24.90	35.30	
AQWLD-17349C20*	MS17349C20*	1.375"-0.1P-0.2L-DS	39.70	28.40		38.50	
AQWLD-17349C22*	MS17349C22*	1.500"-0.1P-0.2L-DS	42.90	30.20		41.70	
AQWLD-17349C24*	MS17349C24*	1.750-0.1P-0.2L-DS	49.30	33.80		48.00	
AQWLD-17349C28*	MS17349C28*	2.000"-0.1P-0.2L-DS	56.40	37.60		54.40	
AQWLD-17349C32*	MS17349C32*	2.250-0.1P-0.2L-DS	62.70	41.10		60.70	
AQWLD-17349C36*	MS17349C36*	2.500-0.1P-0.2L-DS	69.10	45.00		67.10	
AQWLD-17349C40*	MS17349C40*	2.750-0.1P-0.2L-DS	75.40	48.50	73.40	152.40	

*Add attaching ring A, B, or C.

**Plug Dustcap
(AQWLD-17350)**

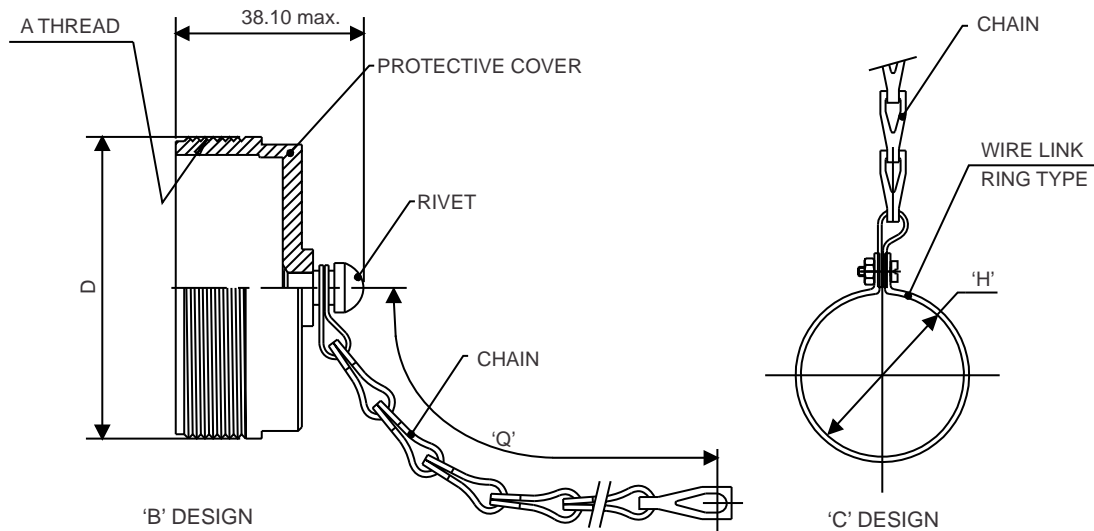

All dimensions are in mm

Amphenol Part No.	MS Part No.	A Thread 2A Double Start	∅D MAX.	∅H MIN.	Q -0.0 +1 LINK
AQWLD-17350C10*	MS17350C10*	0.750-0.1P-0.2L-DS	20.60	18.30	127.00
AQWLD-17350C12*	MS17350C12*	0.875-0.1P-0.2L-DS	23.80	21.40	
AQWLD-17350C14*	MS17350C14*	1.000-0.1P-0.2L-DS	27.00	24.70	
AQWLD-17350C16*	MS17350C16*	1.1250-0.1P-0.2L-DS	30.20	27.70	
AQWLD-17350C18*	MS17350C18*	1.250-0.1P-0.2L-DS	33.30	30.90	
AQWLD-17350C20*	MS17350C20*	1.375"-0.1P-0.2L-DS	36.50	34.00	152.40
AQWLD-17350C22*	MS17350C22*	1.500"-0.1P-0.2L-DS	39.70	37.30	
AQWLD-17350C24*	MS17350C24*	1.750-0.1P-0.2L-DS	46.00	43.60	
AQWLD-17350C28*	MS17350C28*	2.000"-0.1P-0.2L-DS	52.40	50.00	
AQWLD-17350C32*	MS17350C32*	2.250-0.1P-0.2L-DS	58.70	56.30	
AQWLD-17350C36*	MS17350C36*	2.500-0.1P-0.2L-DS	65.10	62.70	
AQWLD-17350C40*	MS17350C40*	2.750-0.1P-0.2L-DS	71.40	70.60	

*Add attaching ring A, B, or C.

Ordering Information

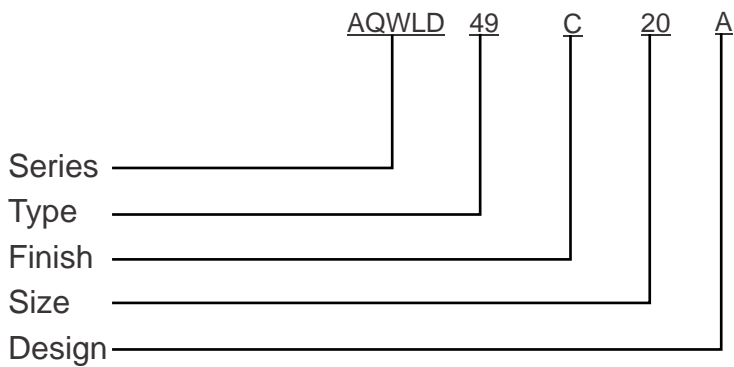

Series
AQWLD

Type
AQWLD 17349 - Cap for Receptacle
AQWLD 17350 - Cap for Plug

Finish
N - Black Anodized (Non-conductive)
C - Cadmium over electroless nickel (Conductive)

Size

12	14	16	18	20	22	24	28	32	36	40
----	----	----	----	----	----	----	----	----	----	----

Design
A - Chain & mounting ring
B - Chain without ring
C - Chain with clip

Contact Details

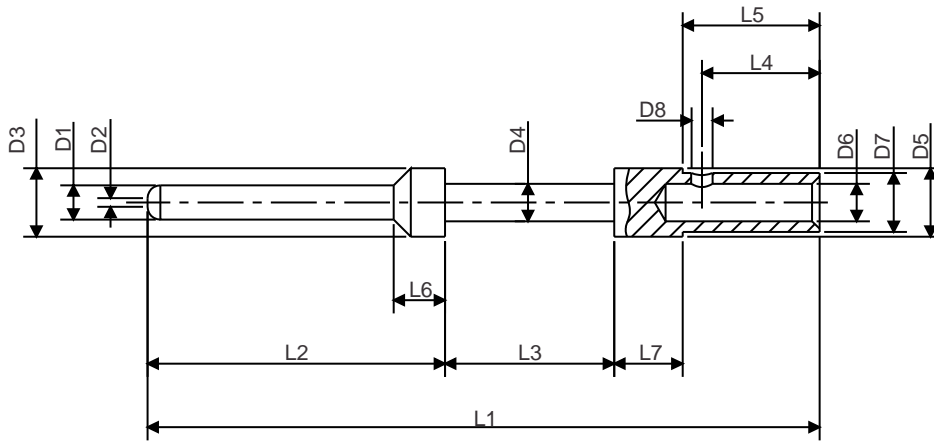

16 & 12 Size Pin Contact (Crimp)

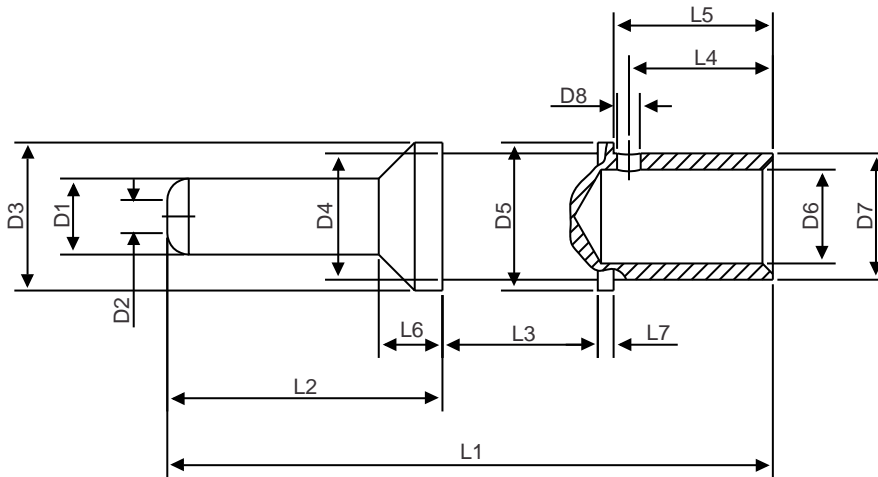

8, 4 & 0 Size Pin Contact (Crimp)

All dimensions are in mm

Contact Size AWG	Contact PART NO.	Wire Size AWG	D1 -0.05	D2 MAX.	D3 -0.1	D4 -0.1	D5 -0.1	D6 +0.08	D7 -0.05	D8	L1 ±0.2	L2 ±0.15	L3 ±0.1	L4 ±0.5	L5 MIN.	L6 ±0.2	L7 ±0.2
16	AQWLD-16-P	16	1.6	0.4	3.2	1.75	3.2	1.75	2.75	1	31.4	13.9	7.9	5.6	6.8	2.4	3.2
12	AQWLD-12-P	12	2.4	0.4	4.8	3.3 -0.15	4.8	2.5 +0.10	3.8 -0.10	1	37.0	18.3	7.9	5.6	6.8	2.4	3.8
8	AQWLD-8-P	8	3.6	0.4	7.6 -0.2	6.25 -0.15	7.6 -0.2	4.55 +0.1	6.8 -0.1	1.8	39.6	20.0	6.35	11.0	12.0	4.0	1.2
4	AQWLD-4-P	4	5.75	2.5	11.2 -0.2	9.55	11.2 -0.2	7.1 +0.15	9.55 -0.1	1.8	39.6	20.0	6.35	11.0	12.0	4.0	1.2
0	AQWLD-0-P	0	9.1	5.8	15.15 -0.2	13.55 -0.15	15.15 -0.2	11.5 +0.15	14.35 -0.1	1.8	41.0	20.0	6.35	12.3	14.0	4.0	1.2

Contact Details

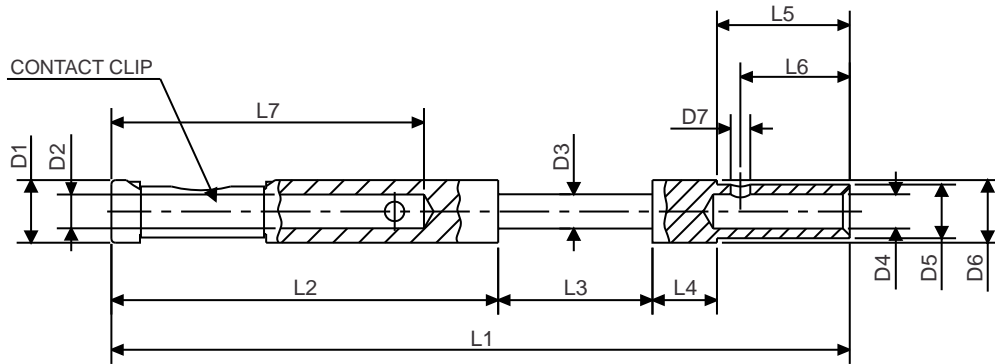

16 & 12 Size Socket Contact

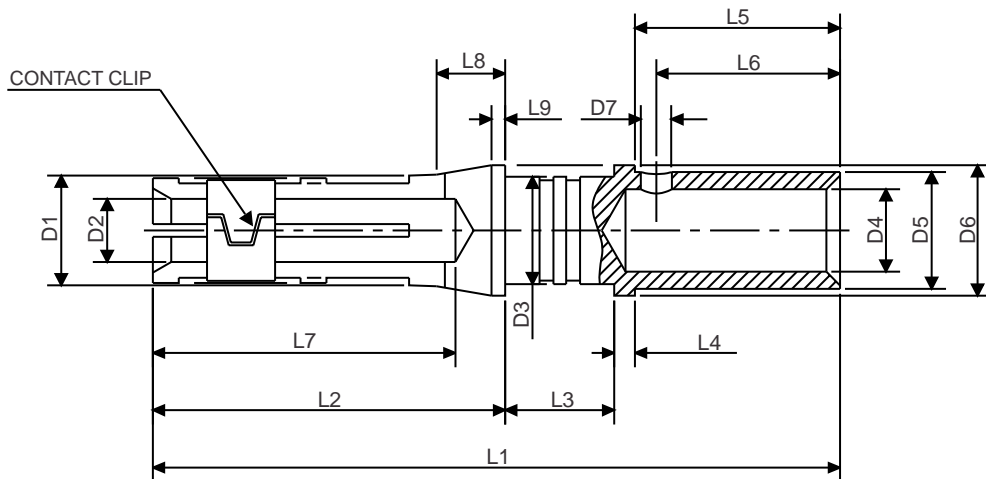

8, 4 & 0 Size Socket Contact

All dimensions are in mm

Contact Size AWG	Contact Part No.	Wire Size AWG	D1 -0.15	D2 +0.30 -0.00	D3 -0.1	D4 +0.08	D5 -0.05	D6 -0.15	D7	L1 ±0.2	L2 ±0.2	L3 ±0.1	L4 ±0.2	L5 MIN.	L6 ±0.5	L7 MIN.	L8 ±0.2	L9 ±0.1
16	AQWLD-16-S	12	3.2	1.65	1.75	1.75	2.75	3.2	1.0	37.8	19.8	7.9	3.3	6.8	5.6	10.5	-	-
12	AQWLD-12-S	-	4.8 -0.1	2.45	3.3	2.5 +0.1	3.8 -0.1	4.8 -0.1	1.0	37.0	19.0 ±0.15	7.9	3.2	6.8	5.6	15.0	-	-
8	AQWLD-8-S	-	6.5 -0.2	3.65	6.25 -0.2	4.8 +0.1	6.8 -0.1	7.6 -0.2	1.8	40.1 ±0.1	20.6 ±0.15	6.35	1.2	12	11.0	15.0	4.0	0.8
4	AQWLD-4-S	-	8.6 -0.2	5.8	9.55 -0.2	7.1	9.55 -0.1	11.2 -0.2	1.8	40.1 ±0.1	20.6 ±0.15	6.35	1.2	12	11.0	15.0	4.0	1.5
0	AQWLD-0-S	-	13.2 -0.2	9.15	13.55 -0.2	11.5 +0.1	14.35 -0.1	15.15 -0.2	1.8	41.6 ±0.1	20.6 ±0.15	6.35	1.2	14	12.3	15.0	4.0	0.8

Ordering Information

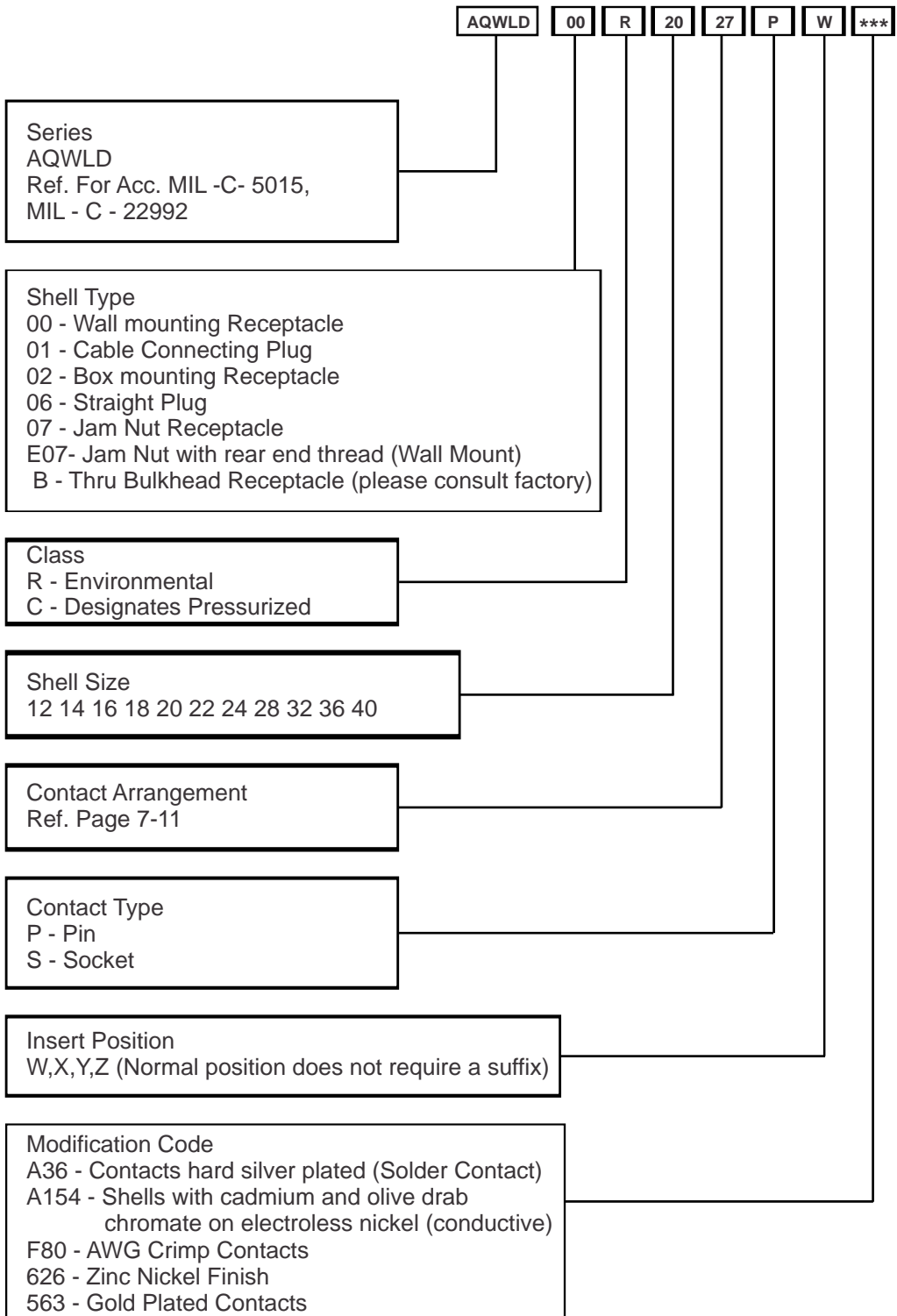

Standard shell finish is non conductive black hard anodic.

Note:

Notice : All information, including illustrations given herein is believed to be accurate at the time of printing. In lieu of design advances, Amphenol reserves the right to change specifications without notice. This publication AQWLD Series Connectors 15-06-09 supercedes all existing Amphenol literature on AQWLD Series Connectors.

Note:

Amphenol

A Global Company



Pune Operations



Bangalore Operations

Amphenol

Interconnect India Pvt. Ltd.

Our offices in India:

MARKETING HEADQUARTERS

105, Bhosari Industrial Area,
Pune - 411 026.
Tel.: 91- 020 - 67360303, 67360304
Fax : 91 - 020 - 67360321
Email : vbhavsar@amphenol-in.com
sales@amphenol-in.com

Southern Region

No. 1115, 22nd Main Road,
11th Cross Sector-1, HSR Layout
Bangalore 560 102
Tel.: 91-80-49530341, 49530345
Fax : 91-80-49538697
Email : kmanoj@amphenol-in.com

Northern and Eastern Region

A-421, Pacific Business Park
Plot No. 37/1, Sahibabad Indst. Area, Site IV,
Ghaziabad (UP) - 201 010.
Mobile : 91-9910211399
Email : sunily@amphenol-in.com

Export

105, Bhosari Industrial Area,
Pune - 411 026, India.
Tel.: 91- 20 - 67360305, 67360353
Fax : 91- 20 - 67360321
Email : svpatil@amphenol-in.com

Western Region

105, Bhosari Industrial Area,
Pune - 411 026.
Tel.: 91-20-67360334
Email : sunilp@amphenol-in.com

Central Region

107, 1st Floor, 'Am Sri Classic',
Sarojinidevi Road, Secunderabad-500 003.
Telefax : 91- 40-66332906
Email : pprasad@amphenol-in.com

Kolkatta

Mobile: 91- 9831533335
Email : rajeshd@amphenol-in.com

Chennai

Mobile: 91- 9940039373
Email : subashs@amphenol-in.com

www.amphenol-in.com